

NBS-507-10-25

SHAFT MOUNT GEAR REDUCER

BOX SIZE 10
RATIO 25:1

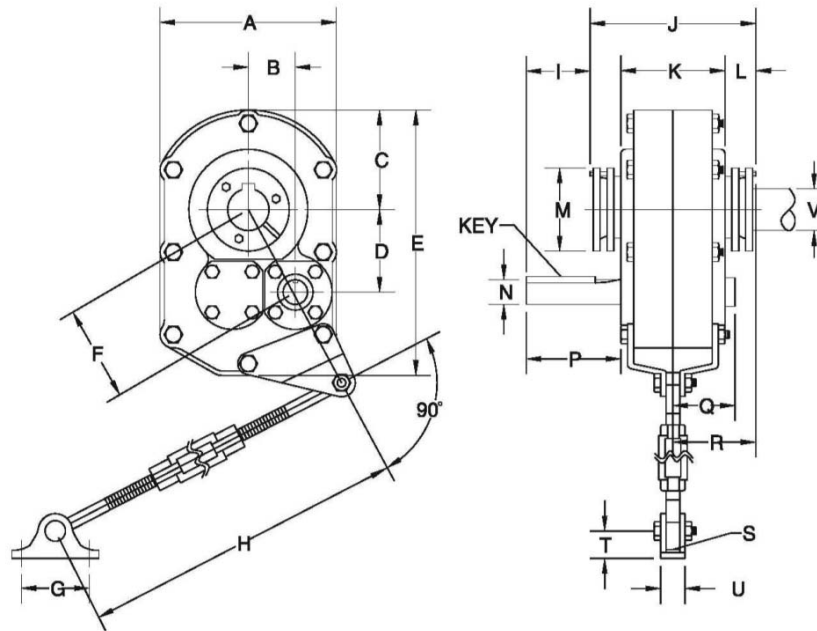

Box Size	Ratio	DIMENSIONS										
		A	B	C	D	E	F	G	H min/max	I	J	K
10	25:1	25.5	6.59	12.75	12.50	35.00	14.13	7.00	30.00/ 36.00	6.53	15.30	9.55

DIMENSIONS							INPUT SHAFT			Weight (Lbs.)
L	M	R	S	T	U	V Max Dia	N Dia	P	Key	
2.78	10.13	7.66	0.75	3.13	4.00	4-15/16	2.69	9.50	5/8 x 5/16 x 7-7/8	1020

NOTE: Torque Arm is included with shaft mount gear reducer.

Optional accessories include:

- Belt Guard**
- Motor Mount**
- Backstops**
- Tapered Bushings**
- Screw Conveyor Adaptor**



NBS-507-10-25

SHAFT MOUNT GEAR REDUCER

BOX SIZE 10
 RATIO 25:1

LUBRICATION INSTRUCTIONS

MOUNTING POSITION	A	B	C	D	E	F
QUARTS	23.000	14.000	15.750	18.750	41.000	41.000
LITERS	21.750	13.250	14.900	17.750	38.800	38.800

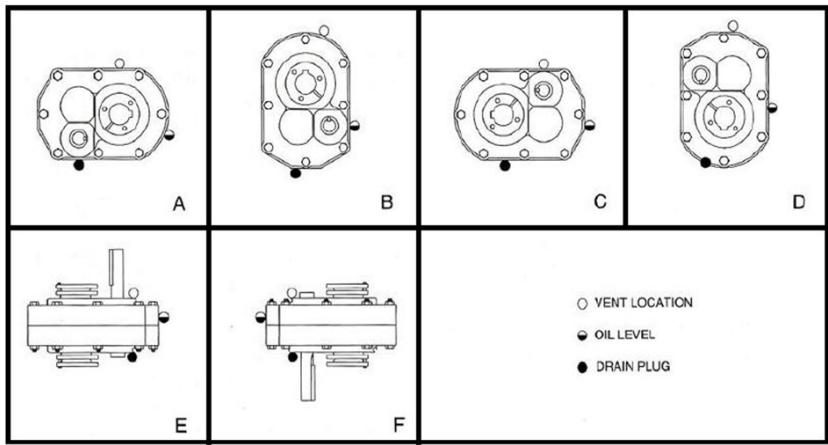

CAUTION

North American Electric Shaft Mount Gear Reducers are SHIPPED WITHOUT OIL. The Reducer must be filled with the proper amount of oil according to the mounting position table above. Failure to fill the case with oil could result in the failure of the reducer and damage to the associated equipment.