



PE143TC-1-4-AI

GENERAL PURPOSE ELECTRIC MOTOR

NEMA PREMIUM EFFICIENCY

THREE PHASE, TOTALLY ENCLOSED FAN COOLED - C-FLANGE W/ FEET

INVERTER DUTY 10:1 CT; 20:1 VT - NEMA MG1 PART 31

Factory Certified for T2B Class I, Division II, Groups A,B,C & D and Class II, Division II, Groups F & G

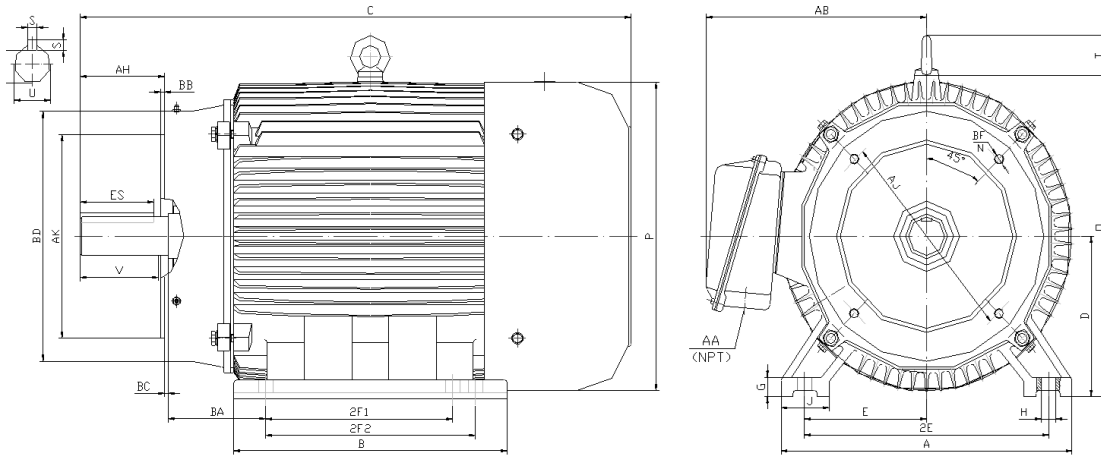

DIMENSIONS

HP	RPM	Frame	MOUNTING														
			A	B	C	D	G	H	J	E	2E	2F1	2F2	O	P	T	BA
1	1800	143TC	7.00	6.25	14.20	3.50	0.43	0.34	1.41	2.75	5.50	4.00	5.00	7.69	8.17	1.42	2.25

FLANGE							Shaft Extension, Key Set						Conduit Box		Bearings		Mount
AH	AJ	AK	BB	BC	BD	BF	U	V	R	S	ES	N-W	AA	AB	DE	ODE	
2.12	5.875	4.50	0.16	0.12	6.50	4*3/8-16	0.875	2.00	0.771	0.189	1.42	2.25	0.75	7.28	6206-ZZ	6206-ZZ	F1

BEARING LUBRICATION: The bearings come lubricated with Mobil Polyrex EM Polyurea Grease.





PE143TC-1-4-AI

GENERAL PURPOSE ELECTRIC MOTOR

NEMA PREMIUM EFFICIENCY

THREE PHASE, TOTALLY ENCLOSED FAN COOLED - C-FLANGE W/ FEET

INVERTER DUTY 10:1 CT; 20:1 VT - NEMA MG1 PART 31

Factory Certified for T2B Class I, Division II, Groups A,B,C & D and Class II, Division II, Groups F & G

PERFORMANCE DATA

HP	RPM	Frame	Voltage	Frequency (Hz)	Full Load S.F.	Insulation Class	NEMA Design	Slip (%)	NEMA Code	Enclosure Type	IP Rating	Max. Ambient
1	1740	143TC	230/460	60	1.15	F	B	3.3	M	TEFC	55	40° C

Amps (460V)		Efficiency (%)				Power Factor			Torque (ft-lb)			DE Bearing	ODE Bearing	Connection	Weight (lbs.)
FLA	LRA	100%	75%	50%	Min.	100%	75%	50%	FLT	LRT %	BDT %				
1.5	15.0	85.5	85.0	83.6	82.5	0.760	0.710	0.580	3.0	300	310	6206-ZZ	6206-ZZ	9 Lead 2Y/Y	65

*Usable at 208 Volts

NAME PLATE

		AC INDUCTION MOTOR INVERTER DUTY 20:1 VT; 10:1 CT									CONNECTION DIAGRAMS				
CAT NO: PE143TC-1-4-AI		FRAME 143TC		PHASE 3								230V 			
HZ 60	S.F. 1.15	HZ 50	S.F. 1.0	ENCL TEFC	IP 55										
HP 1	RPM 1740	HP 1	RPM 1440	DUTY CONT	DES B										
VOLTS 230/460		VOLTS 190/380		AMB 40° C	INS F										
FLA 3 / 1.5	FLA 3.4/1.7		DE BEARING 6206-ZZ												
CODE M	P.F. 0.76	CODE P	P.F. 0.76	ODE BEARING 6206-ZZ											
EFF 85.5	MIN 82.5	EFF 84.0	MIN 81.5	LUB: Mobil Polyrex EM											
MOTOR WEIGHT 65 LBS	CONNECTION 9 Lead 2Y/Y		SER NO												
General purpose use on industrial machinery installed in damp, dusty or dirty environments. Hernando, Mississippi															

APPLICATIONS:

General purpose use on pumps, fans, blowers, compressors, conveyors, material handling and other industrial machinery installed in damp, dusty or dirty environments.