



PE184TD-7.5-2

GENERAL PURPOSE ELECTRIC MOTOR

NEMA PREMIUM EFFICIENCY

TOTALLY ENCLOSED FAN COOLED - D-FLANGE WITH FEET

INVERTER DUTY 10:1 CT; 20:1 VT - NEMA MG1 PART 31

Factory Certified for T2B Class I, Division II, Groups A,B,C & D and Class II, Division II, Groups F & G

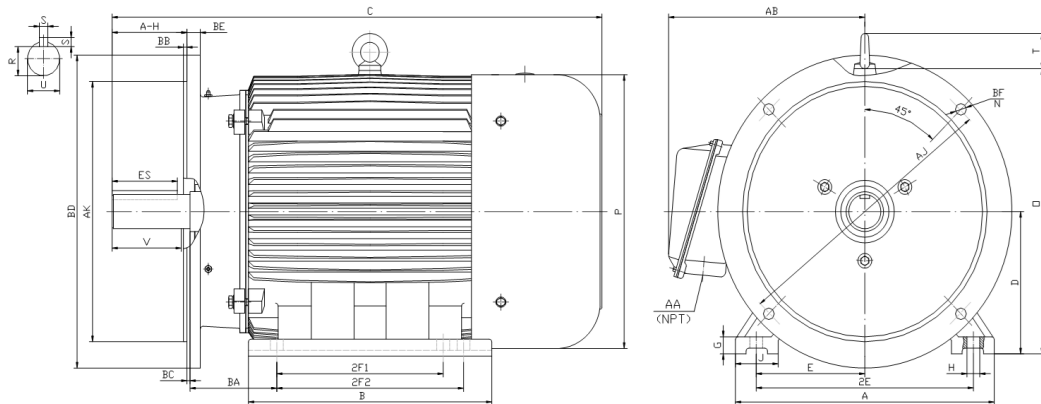

DIMENSIONS

HP	RPM	Frame	MOUNTING														
			A	B	C	D	G	H	J	E	2E	2F1	2F2	O	P	T	BA
7.5	3600	184TD	9.5	8.3	17.1	4.5	0.6	0.41	2	3.75	7.5	4.5	5.5	9.1	8.7	1.6	2.75

FLANGE								Shaft Extension, Key Set						
AH	AJ	AK	BB	BC	BD	BE	BF	U	V	R	S	ES	N-W	
2.75	10	9	0.25	NA	11	0.5	4*0.53	1.125	2.5	0.986	0.25	1.78	NA	

Conduit Box		Bearings		Mount
AA	AB	DE	ODE	
0.75	7.5	6306-ZZ	6306-ZZ	F1

BEARING LUBRICATION: The bearings come lubricated with Mobil Polyrex EM Polyurea Grease.





PE184TD-7.5-2

GENERAL PURPOSE ELECTRIC MOTOR

NEMA PREMIUM EFFICIENCY

TOTALLY ENCLOSED FAN COOLED - D-FLANGE WITH FEET

INVERTER DUTY 10:1 CT; 20:1 VT - NEMA MG1 PART 31

Factory Certified for T2B Class I, Division II, Groups A,B,C & D and Class II, Division II, Groups F & G

PERFORMANCE DATA

HP	RPM	Frame	Voltage	Frequency (Hz)	Full Load S.F.	Insulation Class	NEMA Design	Slip (%)	NEMA Code	Enclosure Type	IP Rating	Max. Ambient
7.5	3500	184TD	230/460	60	1.15	F	B	2.8	H	TEFC	55	40 °C

Amps (460V)		Efficiency (%)			Power Factor			Torque (ft-lb)			DE Bearing	ODE Bearing	Connection	Weight (lbs.)
FLA	LRA	100%	75%	50%	100%	75%	50%	FLT	LRT %	BDT %				
8.8	63	89.5	89.0	88.0	0.90	0.83	0.73	11.3	190	300	6306-ZZ	6306-ZZ	9 Lead 2Y/Y	131

*Usable at 208 Volts

NAME PLATE

		AC INDUCTION MOTOR INVERTER DUTY 20:1 VT; 10:1 CT						CONNECTION DIAGRAMS		
CAT NO. PE184TD-7.5-2		FRAME 184TD		PHASE 3		230V				
HZ 60	S.F. 1.15	HZ 50	S.F. 1.0	ENCL TEFC	IP 55					
HP 7.5	RPM 3500	HP 7.5	RPM 2880	DUTY CONT	DES B					
VOLTS 230/460		VOLTS 190/380		AMB 40 °C	INS F					
AMPS 17.6 / 8.8		AMPS 22/11		DE BRG 6306-ZZ						
CODE H	P.F. 0.90	CODE E	P.F. 0.92	ODE BRG 6306-ZZ						
EFF 89.5	MIN 87.5	EFF 87.5	MIN 85.5	LUB: Mobil Polyrex EM						
MOTOR WEIGHT 131 LBS		CONNECTION 9 Lead 2Y/Y		SER NO						
General purpose use on industrial machinery installed in damp, dusty or dirty environments. Hernando, Mississippi								CC082A		

APPLICATIONS:

General purpose use on pumps, fans, blowers, compressors, conveyors, material handling and other industrial machinery installed in damp, dusty or dirty environments.