



## PE213TC-3-6

GENERAL PURPOSE ELECTRIC MOTOR

NEMA PREMIUM EFFICIENCY

TOTALLY ENCLOSED FAN COOLED - C-FLANGE WITH FEET

INVERTER DUTY 10:1 CT; 20:1 VT - NEMA MG1 PART 31

Factory Certified for T2B Class I, Division II, Groups A,B,C & D and Class II, Division II, Groups F & G

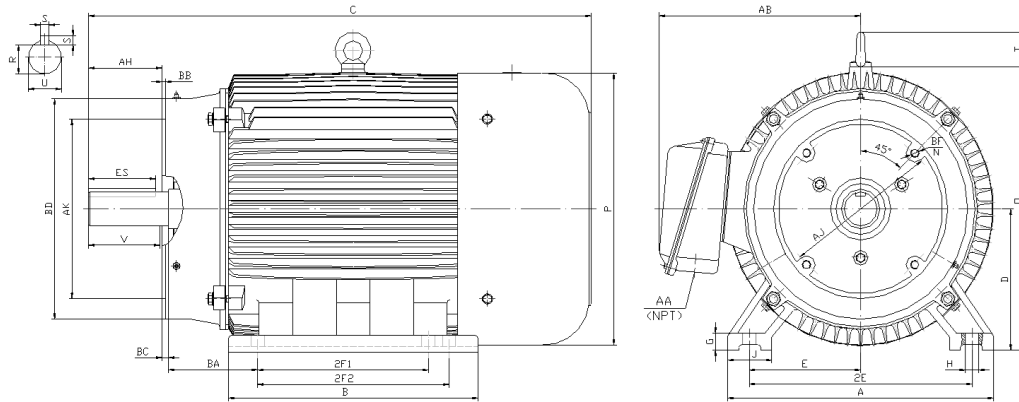

### DIMENSIONS

HP	RPM	Frame	MOUNTING														
			A	B	C	D	G	H	J	E	2E	2F1	2F2	O	P	T	BA
3	1200	213TC	11	7.9	18.9	5.25	0.7	0.41	2.4	4.25	8.5	5.5	NA	11.2	11.6	1.9	3.5

FLANGE							Shaft Extension, Key Set						
AH	AJ	AK	BB	BC	BD	BF	U	V	R	S	ES	N-W	
3.12	7.25	8.5	0.25	0.25	9	4*1/2-13	1.375	3.12	1.201	0.312	2.41	NA	

Conduit Box		Bearings		Mount
AA	AB	DE	ODE	
1	9	6308-ZZ	6308-ZZ	F1

**BEARING LUBRICATION:** The bearings come lubricated with Mobil Polyrex EM Polyurea Grease.





## PE213TC-3-6

GENERAL PURPOSE ELECTRIC MOTOR

NEMA PREMIUM EFFICIENCY

TOTALLY ENCLOSED FAN COOLED - C-FLANGE WITH FEET

INVERTER DUTY 10:1 CT; 20:1 VT - NEMA MG1 PART 31

Factory Certified for T2B Class I, Division II, Groups A,B,C & D and Class II, Division II, Groups F & G

### PERFORMANCE DATA

HP	RPM	Frame	Voltage	Frequency (Hz)	Full Load S.F.	Insulation Class	NEMA Design	Slip (%)	NEMA Code	Enclosure Type	IP Rating	Max. Ambient
3	1185	213TC	208-230/460	60	1.15	F	B	1.3	K	TEFC	55	40 °C

Amps (460V)		Efficiency (%)			Power Factor			Torque (ft-lb)			DE Bearing	ODE Bearing	Connection	Weight (lbs.)
FLA	LRA	100%	75%	50%	100%	75%	50%	FLT	LRT %	BDT %				
4.2	32	89.5	89.0	87.0	0.70	0.63	0.50	13.47	190	280	6308-ZZ	6308-ZZ	9 Lead 2Y/Y	150

### NAME PLATE

		AC INDUCTION MOTOR INVERTER DUTY 20:1 VT; 10:1 CT								CONNECTION DIAGRAMS		
CAT NO. PE213TC-3-6		FRAME 213TC		PHASE 3								
HZ 60	S.F. 1.15	HZ 50	S.F. 1.0	ENCL TEFC	IP 55							
HP 3	RPM 1185	HP 3	RPM 980	DUTY CONT	DES B							
VOLTS 208-230/460		VOLTS 190/380		AMB 40 °C	INS F							
AMPS 9.2 - 8.4 / 4.2		AMPS 10.4/5.2		DE BRG 6308-ZZ								
CODE K	P.F. 0.70	CODE H	P.F. 0.75	ODE BRG 6308-ZZ								
EFF 89.5	MIN 87.5	EFF 85.5	MIN 83.5	LUB: Mobil Polyrex EM								
MOTOR WEIGHT 150	LBS	CONNECTION 9 Lead 2Y/Y		SER NO								
General purpose use on industrial machinery installed in damp, dusty or dirty environments. Hernando, Mississippi								CC082A				

### APPLICATIONS:

General purpose use on pumps, fans, blowers, compressors, conveyors, material handling and other industrial machinery installed in damp, dusty or dirty environments.