

PE215TC-10-4

GENERAL PURPOSE ELECTRIC MOTOR

NEMA PREMIUM EFFICIENCY

TOTALLY ENCLOSED FAN COOLED - C-FLANGE WITH FEET

INVERTER DUTY 10:1 CT; 20:1 VT - NEMA MG1 PART 31

Factory Certified for T2B Class I, Division II, Groups A,B,C & D and Class II, Division II, Groups F & G

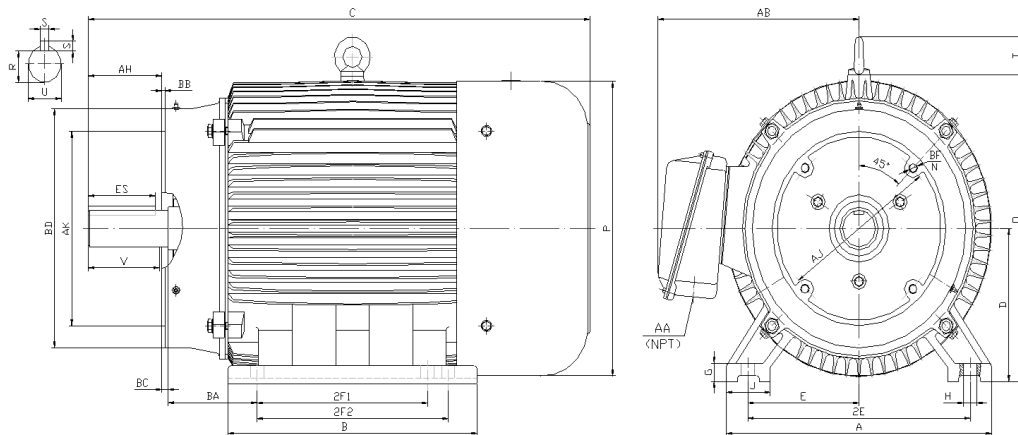

DIMENSIONS

HP	RPM	Frame	MOUNTING														
			A	B	C	D	G	H	J	E	2E	2F1	2F2	O	P	T	BA
10	1800	215TC	11	9.4	20.4	5.25	0.7	0.41	2.4	4.25	8.5	5.5	7	10.5	10.2	1.9	3.5

FLANGE							Shaft Extension, Key Set					
AH	AJ	AK	BB	BC	BD	BF	U	V	R	S	ES	N-W
3.12	7.25	8.5	0.25	0.25	9	4*1/2-13	1.375	3.12	1.201	0.312	2.41	NA

Conduit Box		Bearings		Mount
AA	AB	DE	ODE	
1	8.3	6308-ZZ	6308ZZ	F1

BEARING LUBRICATION: The bearings come lubricated with Mobil Polyrex EM Polyurea Grease.



PE215TC-10-4

GENERAL PURPOSE ELECTRIC MOTOR

NEMA PREMIUM EFFICIENCY

TOTALLY ENCLOSED FAN COOLED - C-FLANGE WITH FEET

INVERTER DUTY 10:1 CT; 20:1 VT - NEMA MG1 PART 31

Factory Certified for T2B Class I, Division II, Groups A,B,C & D and Class II, Division II, Groups F & G

PERFORMANCE DATA

HP	RPM	Frame	Voltage	Frequency (Hz)	Full Load S.F.	Insulation Class	NEMA Design	Slip (%)	NEMA Code	Enclosure Type	IP Rating	Max. Ambient
10	1770	215TC	230/460	60	1.15	F	B	1.7	H	TEFC	55	40 °C

Amps (460V)		Efficiency (%)			Power Factor			Torque (ft-lb)			DE Bearing	ODE Bearing	Connection	Weight (lbs.)
FLA	LRA	100%	75%	50%	100%	75%	50%	FLT	LRT %	BDT %				
12	81	91.7	91.8	90.0	0.81	0.77	0.67	30.02	170	280	6308-ZZ	6308-ZZ	9 Lead 2Y/Y	181

*Usable at 208 Volts

NAME PLATE

		AC INDUCTION MOTOR INVERTER DUTY 20:1 VT; 10:1 CT						CONNECTION DIAGRAMS		
CAT NO. PE215TC-10-4		FRAME 215TC		PHASE 3		230V 				
HZ 60	S.F. 1.15	HZ 50	S.F. 1.0	ENCL TEFC	IP 55					
HP 10	RPM 1770	HP 10	RPM 1460	DUTY CONT	DES B					
VOLTS 230/460		VOLTS 190/380		AMB 40 °C	INS F					
AMPS 24 / 12		AMPS 30/15		DE BRG 6308-ZZ						
CODE H	P.F. 0.81	CODE F	P.F. 0.84	ODE BRG 6308-ZZ						
EFF 91.7	MIN 90.2	EFF 89.7	MIN 88.2	LUB: Mobil Polyrex EM						
MOTOR WEIGHT 181 LBS		CONNECTION 9 Lead 2Y/Y		SER NO		460V 				
General purpose use on industrial machinery installed in damp, dusty or dirty environments. Hernando, Mississippi								CC082A		

APPLICATIONS:

General purpose use on pumps, fans, blowers, compressors, conveyors, material handling and other industrial machinery installed in damp, dusty or dirty environments.