



## PE286T-30-4-AI

GENERAL PURPOSE ELECTRIC MOTOR

NEMA PREMIUM EFFICIENCY

TOTALLY ENCLOSED FAN COOLED

INVERTER DUTY 10:1 CT; 20:1 VT - NEMA MG1 PART 31

Factory Certified for T2B Class I, Division II, Groups A,B,C & D and Class II, Division II, Groups F & G

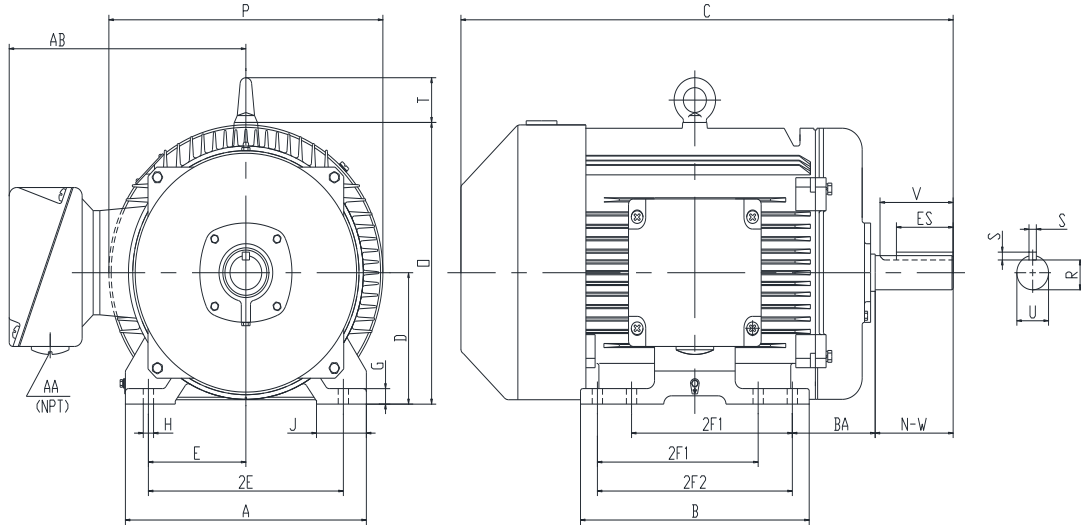

### DIMENSIONS

HP	RPM	Frame	MOUNTING														
			A	B	C	D	G	H	J	E	2E	2F1	2F2	O	P	T	BA
30	1800	286T	14	13.4	28.8	7	0.8	0.53	2.75	5.5	11	9.5	11	14.8	15.71	2.05	4.75

Shaft Extension, Key Set						Conduit Box		Bearings		Mount
U	V	R	S	ES	N-W	AA	AB	DE	ODE	
1.875	4.38	1.591	0.5	3.28	4.62	1.5	12.4	6311	6311	F1

**BEARING LUBRICATION:** The bearings come lubricated with Mobil Polyrex EM Polyurea Grease. It is recommended that you add some additional lubrication when the motor is installed.

Three options (brands) for suitable lubrication include, but are not limited to, the following:

- 1.) Mobil Polyrex EM
- 2.) Citco Polyurea MP
- 3.) Conoco Phillips Polytac EP





## PE286T-30-4-AI

GENERAL PURPOSE ELECTRIC MOTOR

NEMA PREMIUM EFFICIENCY

TOTALLY ENCLOSED FAN COOLED

INVERTER DUTY 10:1 CT; 20:1 VT - NEMA MG1 PART 31

Factory Certified for T2B Class I, Division II, Groups A,B,C & D and Class II, Division II, Groups F & G

### PERFORMANCE DATA

HP	RPM	Frame	Voltage	Frequency (Hz)	Full Load S.F.	Insulation Class	NEMA Design	Slip (%)	NEMA Code	Enclosure Type	IP Rating	Max. Ambient
30	1760	286T	230/460	60	1.15	F	B	2.2	G	TEFC	55	40 °C

Amps (460V)		Efficiency (%)			Power Factor			Torque (ft-lb)			DE Bearing	ODE Bearing	Connection	Weight (lbs.)
FLA	LRA	100%	75%	50%	100%	75%	50%	FLT	LRT %	BDT %				
34	217	93.6	93.2	93.7	0.90	0.88	0.80	89.1	185	280	6311	6311	12 Lead 2Δ/Δ	484

\*Usable at 208 Volts

### NAME PLATE

		AC INDUCTION MOTOR INVERTER DUTY 20:1 VT; 10:1 CT						CONNECTION DIAGRAMS		
CAT NO. PE286T-30-4-AI		FRAME 286T		PHASE 3						
HZ 60	S.F. 1.15	HZ 50	S.F. 1.0	ENCL TEFC	IP 55					
HP 30	RPM 1760	HP 30	RPM 1470	DUTY CONT	DES B					
VOLTS 230/460		VOLTS 190/380		AMB 40 °C	INS F					
AMPS 68/34		AMPS 83.6/41.8		DE BRG 6311						
CODE G	P.F. 0.90	CODE H	P.F. 0.90	ODE BRG 6311						
EFF 93.6	MIN 92.4	EFF 93.0	MIN 91.7	LUB: Mobil Polyrex EM						
MOTOR WEIGHT 484	LBS	CONNECTION 12 Lead 2Δ/Δ		SER NO						
General purpose use on industrial machinery installed in damp, dusty or dirty environments. Hernando, Mississippi								CC113B 263262		

### APPLICATIONS:

General purpose use on pumps, fans, blowers, compressors, conveyors, material handling and other industrial machinery installed in damp, dusty or dirty environments.