



PE364TS-60-2

GENERAL PURPOSE ELECTRIC MOTOR

NEMA PREMIUM EFFICIENCY

TOTALLY ENCLOSED FAN COOLED

INVERTER DUTY 10:1 CT; 20:1 VT - NEMA MG1 PART 31

Factory Certified for T2B Class I, Division II, Groups A,B,C & D and Class II, Division II, Groups F & G

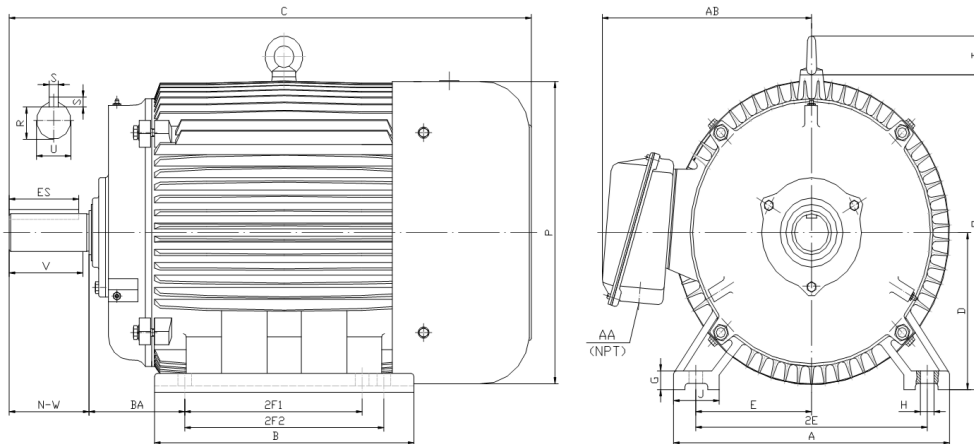

DIMENSIONS

HP	RPM	Frame	MOUNTING														
			A	B	C	D	G	H	J	E	2E	2F1	2F2	O	P	T	BA
60	3600	364TS	17.1	15.4	31.4	9	1.15	0.66	2.95	7	14	11.25	12.25	18.1	17.6	2.6	5.88

Shaft Extension, Key Set						Conduit Box		Bearings		Mount
U	V	R	S	ES	N-W	AA	AB	DE	ODE	
1.875	3.5	1.591	0.5	2.03	3.75	3	14.6	6313	6313	F1

BEARING LUBRICATION: The bearings come lubricated with Mobil Polyrex EM Polyurea Grease. It is recommended that you add some additional lubrication when the motor is installed.

Three options (brands) for suitable lubrication include, but are not limited to, the following:

- 1.) Mobil Polyrex EM
- 2.) Citco Polyurea MP
- 3.) Conoco Phillips Polytac EP





PE364TS-60-2

GENERAL PURPOSE ELECTRIC MOTOR

NEMA PREMIUM EFFICIENCY

TOTALLY ENCLOSED FAN COOLED

INVERTER DUTY 10:1 CT; 20:1 VT - NEMA MG1 PART 31

Factory Certified for T2B Class I, Division II, Groups A,B,C & D and Class II, Division II, Groups F & G

PERFORMANCE DATA

HP	RPM	Frame	Voltage	Frequency (Hz)	Full Load S.F.	Insulation Class	NEMA Design	Slip (%)	NEMA Code	Enclosure Type	IP Rating	Max. Ambient
60	3565	364TS	230/460	60	1.15	F	B	1.0	G	TEFC	55	40 °C

Amps (460V)		Efficiency (%)			Power Factor			Torque (ft-lb)			DE Bearing	ODE Bearing	Connection	Weight (lbs.)
FLA	LRA	100%	75%	50%	100%	75%	50%	FLT	LRT %	BDT %				
66	435	93.6	93.0	92.4	0.92	0.90	0.85	88.55	140	255	6313	6313	12 Lead 2Δ/Δ	805

*Usable at 208 Volts

NAME PLATE

		AC INDUCTION MOTOR INVERTER DUTY 20:1 VT; 10:1 CT						CONNECTION DIAGRAMS		
CAT NO. PE364TS-60-2		FRAME 364TS		PHASE 3		230V 				
HZ 60	S.F. 1.15	HZ 50	S.F. 1.0	ENCL TEFC	IP 55					
HP 60	RPM 3565	HP 60	RPM 2960	DUTY CONT	DES B					
VOLTS 230/460		VOLTS 190/380		AMB 40 °C	INS F					
AMPS 132 / 66		AMPS 160/80		DE BRG 6313						
CODE G	P.F. 0.92	CODE F	P.F. 0.93	ODE BRG 6313						
EFF 93.6	MIN 92.4	EFF 92.0	MIN 90.8	LUB: Mobil Polyrex EM		460V 				
MOTOR WEIGHT 805 LBS		CONNECTION 12 Lead 2Δ/Δ		SER NO						
General purpose use on industrial machinery installed in damp, dusty or dirty environments. Hernando, Mississippi								CC082A		

APPLICATIONS:

General purpose use on pumps, fans, blowers, compressors, conveyors, material handling and other industrial machinery installed in damp, dusty or dirty environments.