



PE365TSC-75-4

GENERAL PURPOSE ELECTRIC MOTOR

NEMA PREMIUM EFFICIENCY

TOTALLY ENCLOSED FAN COOLED - C-FLANGE WITH FEET

INVERTER DUTY 10:1 CT; 20:1 VT - NEMA MG1 PART 31

Factory Certified for T2B Class I, Division II, Groups A,B,C & D and Class II, Division II, Groups F & G

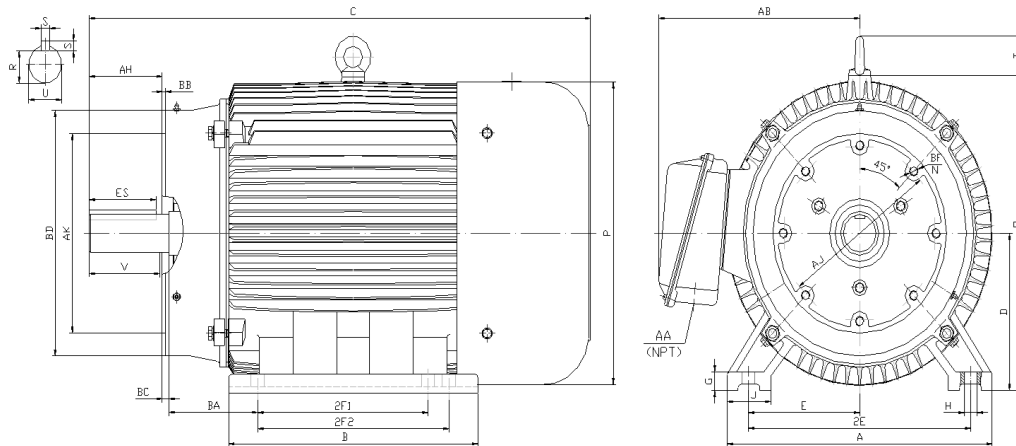

DIMENSIONS

HP	RPM	Frame	MOUNTING														
			A	B	C	D	G	H	J	E	2E	2F1	2F2	O	P	T	BA
75	1800	365TSC	17.1	15.4	31.4	9	1.15	0.66	2.95	7	14	11.25	12.25	18.5	18.4	2.6	5.88

FLANGE							Shaft Extension, Key Set						
AH	AJ	AK	BB	BC	BD	BF	U	V	R	S	ES	N-W	
3.5	11	12.5	0.25	0.25	14	8*5/8-11	1.875	3.5	1.591	0.5	2.03	NA	

Conduit Box		Bearings		Mount
AA	AB	DE	ODE	
3	15	6313	6313	F1

BEARING LUBRICATION: The bearings come lubricated with Mobil Polyrex EM Polyurea Grease. It is recommended that you add some additional lubrication when the motor is installed.

Three options (brands) for suitable lubrication include, but are not limited to, the following:

- 1.) Mobil Polyrex EM
- 2.) Citco Polyurea MP
- 3.) Conoco Phillips Polytac EP





PE365TSC-75-4

GENERAL PURPOSE ELECTRIC MOTOR

NEMA PREMIUM EFFICIENCY

TOTALLY ENCLOSED FAN COOLED - C-FLANGE WITH FEET

INVERTER DUTY 10:1 CT; 20:1 VT - NEMA MG1 PART 31

Factory Certified for T2B Class I, Division II, Groups A,B,C & D and Class II, Division II, Groups F & G

PERFORMANCE DATA

HP	RPM	Frame	Voltage	Frequency (Hz)	Full Load S.F.	Insulation Class	NEMA Design	Slip (%)	NEMA Code	Enclosure Type	IP Rating	Max. Ambient
75	1780	365TSC	230-460	60	1.15	F	B	1.1	G	TEFC	55	40 °C

Amps (460V)		Efficiency (%)			Power Factor			Torque (ft-lb)			DE Bearing	ODE Bearing	Connection	Weight (lbs.)
FLA	LRA	100%	75%	50%	100%	75%	50%	FLT	LRT %	BDT %				
87	542	95.4	95.5	95.5	0.85	0.82	0.75	221.95	160	250	6313	6313	12 Lead 2Δ/Δ	881

*Usable at 208 Volts

NAME PLATE

		AC INDUCTION MOTOR INVERTER DUTY 20:1 VT; 10:1 CT						CONNECTION DIAGRAMS		
CAT NO. PE365TSC-75-4		FRAME 365TSC		PHASE 3			230V			
HZ 60	S.F. 1.15	HZ 50	S.F. 1.0	ENCL TEFC	IP 55					
HP 75	RPM 1780	HP 75	RPM 1480	DUTY CONT	DES B					
VOLTS 230-460		VOLTS 190/380		AMB 40 °C	INS F					
AMPS 174 / 87		AMPS 210/105		DE BRG 6313						
CODE G	P.F. 0.85	CODE F	P.F. 0.86	ODE BRG 6313						
EFF 95.4	MIN 94.5	EFF 94.0	MIN 93.1	LUB: Mobil Polyrex EM		460V				
MOTOR WEIGHT 881	LBS	CONNECTION 12 Lead 2Δ/Δ		SER NO						
General purpose use on industrial machinery installed in damp, dusty or dirty environments. Hernando, Mississippi								CC082A		

APPLICATIONS:

General purpose use on pumps, fans, blowers, compressors, conveyors, material handling and other industrial machinery installed in damp, dusty or dirty environments.