

## PE587UZ-500-6C

CRUSHER DUTY MOTOR

HIGH TORQUE / PREMIUM EFFICIENCY DESIGN

TOTALLY ENCLOSED FAN COOLED

HEAVY DUTY CAST IRON CONSTRUCTION

Factory Certified for T2B Class I, Division II, Groups A,B,C & D and Class II, Division II, Groups F & G

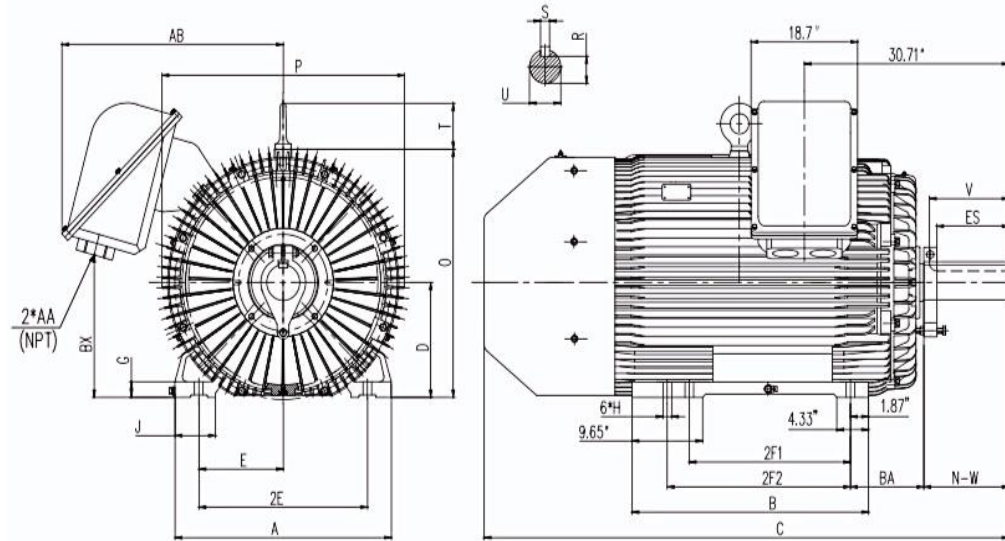

### DIMENSIONS

HP	RPM	Frame	MOUNTING														
			A	B	C	D	G	H	J	E	2E	2F1	2F2	O	P	T	BA
500	1200	587UZ	29.53	32.3	71.65	14.5	1.97	1.18	5.51	11.5	23	22	25	41.44	33.07	5.8	10

Shaft Extension, Key Set						Conduit Box			Bearings		Mount
U	V	R	S	ES	N-W	AA	AB	BX	DE	ODE	
4.375	11.25	3.817	1	10	11.625	2 X 3"	28.15	18.82	NU324	6319	F1

**BEARING LUBRICATION:** The bearings come lubricated with Mobil Polyrex EM Polyurea Grease. It is recommended that you add some additional lubrication when the motor is installed.

Three options (brands) for suitable lubrication include, but are not limited to, the following:

- 1.) Mobil Polyrex EM
- 2.) Citco Polyurea MP
- 3.) Conoco Phillips Polytac EP



## PE587UZ-500-6C

**CRUSHER DUTY MOTOR**

**HIGH TORQUE / PREMIUM EFFICIENCY DESIGN**

**TOTALLY ENCLOSED FAN COOLED**

**HEAVY DUTY CAST IRON CONSTRUCTION**

**Factory Certified for T2B Class I, Division II, Groups A,B,C & D and Class II, Division II, Groups F & G**

### PERFORMANCE DATA

HP	RPM	Frame	Voltage	Frequency (Hz)	Full Load S.F.	Insulation Class	NEMA Design	Slip (%)	NEMA Code	Enclosure Type	IP Rating	Max. Ambient
500	1189	587UZ	460	60	1.15	F	C	0.9	G	TEFC	55	40 °C

Amps (460V)		Efficiency (%)			Power Factor			Torque (ft-lb)			DE Bearing	ODE Bearing	Connection	Weight (lbs.)
FLA	LRA	100%	75%	50%	100%	75%	50%	FLT	LRT %	BDT %				
563.1	3625	95.8	95.4	95.0	0.86	0.83	0.77	2211	200	275	NU324	6319	12 Lead Δ	6190.8

### NAME PLATE

										<b>AC INDUCTION MOTOR</b> HIGH EFFICIENCY DESIGN <b>CRUSHER DUTY MOTOR</b>										<b>CONNECTION DIAGRAMS</b>		
CAT. NO. PE587UZ-500-6C				FRAME 587UZ				PHASE 3		ENCL. TEFC				<div style="text-align: center;">460V</div>								
RATING CONT				INS. CLASS F				CONN. 12 Lead Δ														
DE BRG. NU324				ODE BRG. 6319				LUB. Mobil Polyrex EM														
MAX. AMB. 40 °C				WEIGHT 6190.8				SER.														
60 HERTZ DATA		HP 500		RPM 1189		HP 500		RPM 990		50 HERTZ DATA												
VOLTS 460				VOLTS 380																		
F.L. AMPS 563.1				F.L. AMPS 681.6																		
S.F. AMPS 647.565				S.F. AMPS 681.6																		
S.F. 1.15		DESIGN C		CODE G		S.F. 1.0		DESIGN C		CODE H												
NEMA NOM.EFF 95.4		NOM. P.F. 0.83		NEMA NOM.EFF 95.0		NOM. P.F. 0.86																
NEMA MIN.EFF 95.0		MAX. KVAR 81.3		NEMA MIN.EFF 94.3		MAX. KVAR 84.5																
PLATINUM RTD 3XPT100						SPACE HEATER 1X200W 115V(H1,H2)																
Designed specifically for use on crushing and pulverizing equipment and other equipment requiring extremely high starting torques and breakdown torques.												CC041B										
Hernando, MS 38632																						

### APPLICATIONS:

Special purpose use on crushing and pulverizing equipment and other industrial equipment requiring extremely high starting torques and breakdown torques.