

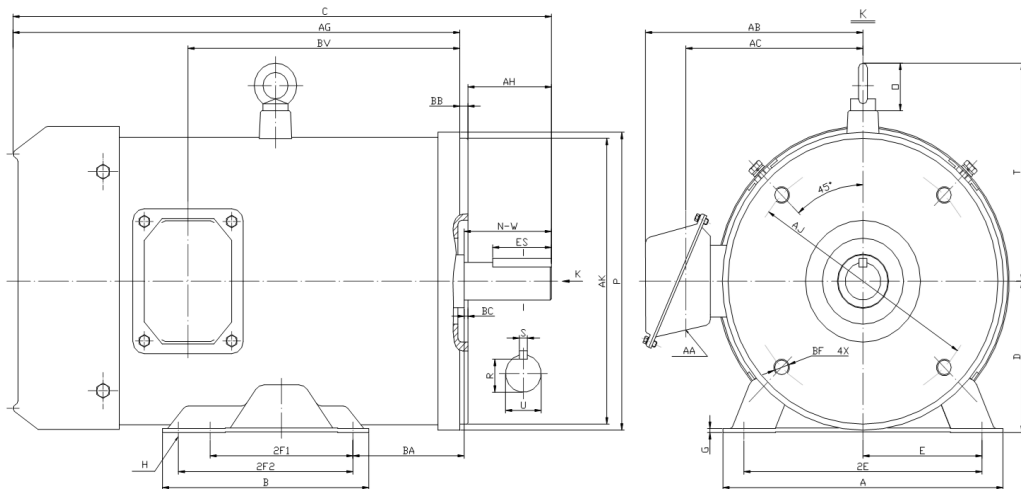

PESS213TC7.5M-2

WASHDOWN DUTY MOTOR
NEMA PREMIUM EFFICIENCY
STAINLESS STEEL CONSTRUCTION - C-FLANGE WITH FEET
TOTALLY ENCLOSED FAN COOLED - IP66 CONSTRUCTION
INVERTER DUTY 10:1 CT; 20:1 VT - NEMA MG1 PART 31



DIMENSIONS

HP	RPM	Frame	MOUNTING													
			A	B	C	D	G	H	E	2E	2F1	2F2	P	AG	BA	
7.5	3600	213TC	9.6	8.1	20.7	5.25	0.157	0.41	4.25	8.5	5.5	7	10.08	17.33	4.25	

FLANGE						Shaft Extension, Key Set					Conduit Box			
AH	AJ	AK	BB	BC	BF	U	R	S	ES	N-W	AA	AB	AC	BV
3.12	7.25	8.5	0.25	0.25	4*1/2-13	1.375	1.201	0.312	2.41	3.38	0.94	7.7	6.2	11.35

Bearings		Mount
DE	ODE	
6308-2RS	6208-2RS	F1

BEARING LUBRICATIONS: The sealed bearings come lubricated with NEVASTANE XS 80 Grease which complies with FDA Chapter 21 CFR 178.3570





PESS213TC7.5M-2

WASHDOWN DUTY MOTOR
NEMA PREMIUM EFFICIENCY
STAINLESS STEEL CONSTRUCTION - C-FLANGE WITH FEET
TOTALLY ENCLOSED FAN COOLED - IP66 CONSTRUCTION
INVERTER DUTY 10:1 CT; 20:1 VT - NEMA MG1 PART 31

PERFORMANCE DATA

HP	RPM	Frame	Voltage	Frequency (Hz)	Full Load S.F.	Insulation Class	NEMA Design	Slip (%)	NEMA Code	Enclosure Type	IP Rating	Max. Ambient
7.5	3520	213TC	230/460	60	1.15	F	B	2.2	H	TEFC	66	40 °C

Amps (460V)		Efficiency (%)			Power Factor			Torque (ft-lb)			DE Bearing	ODE Bearing	Connection	Weight (lbs.)
FLA	LRA	100%	75%	50%	100%	75%	50%	FLT	LRT %	BDT %	6308-2RS	6208-2RS	9 Lead 2Y/Y	151
9.5	63.5	89.5	88.0	88.0	0.85	0.80	0.68	11.1	250	270				

*Usable at 208 Volts

NAME PLATE

		THREE PHASE AC INDUCTION MOTOR INVERTER DUTY 20:1 VT; 10:1 CT						Hernando, MS 38632					
Model :		PESS213TC7.5M-2				IP	66	FRAME	213TC	LB/WT	151		
HZ	60	S.F.	1.15	HZ	50	S.F.	1.0	NEMA DESIGN	B				
HP	7.5	RPM	3520	HP	7.5	RPM	2915	ENCL.	TEFC	INS	F		
VOLTS		230/460		VOLTS		190/380		DUTY	CONT	AMB		40 °C	
AMPS		19/9.5		AMPS		22.4/11.2		DE BRG		6308-2RS			
CODE	H	P.F.	0.85	CODE	K	P.F.	0.87	ODE BRG		6208-2RS			
EFF	89.5	MIN	87.5	EFF	87.5	MIN	85.5	SER NO.					
								CC082A		MADE IN CHINA			

Factory Certified for T2B
 Div 2. Class I, Gr. A , B , C & D
 and Class II, Gr. F & G

APPLICATIONS:

Applications include washdown applications, food processing, chemical processing, pharmaceuticals, poultry processing, meat processing, dairy applications, bakeries, snack foods, bottling and extremely corrosive environments.